

Model-No.: DFB-0852-150, DFB Diode Laser



Description: The DFB-0852-150 is a high power MOVPE grown GaAsP/AlGaAs Distributed Feedback diode laser. The chips are mounted in 9mm TO-can. The diode laser operates spatially and longitudinally single mode. Manufacturer is Eagleyard Photonics.

Wavelength: Selected for Cesium applications

Characteristics: The characteristics are measured at 25°C operation temperature.

Paramter	Symbol	Unit	Min.	typ.	max.
Center Wavelength	λ_c	nm	849	852	855
Spectral Width	$\Delta\lambda$	MHz		5	10
Temperature Coefficient	$\Delta T/\Delta\lambda$	nm/K		0.08	
Output Power	P_{opt}	mW		100	150
Slope Efficiency	η	mW/mA	0.6	0.8	1.0
Threshold Current	I_{th}	mA	60	70	90
Operation Current @ 100mW	I_{op}	mA		230	250
Chip Length	L_c	μm		1500	
Emitter width	W_c	μm		4	
Beam Divergence (FWHM)	$\theta_{ }$	deg.	6	8	10
Beam Divergence \perp (FWHM)	θ_{\perp}	deg.	18	21	24
Polarzation				TE	
Mode Structure			fundamental transverse mode		

Laser Mount: 9mm TO-can with monitor diode

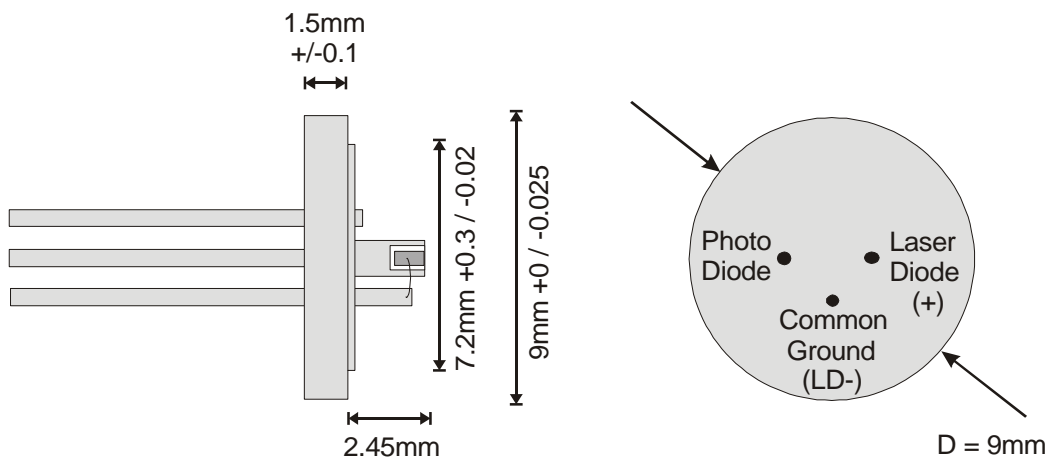

Side View of the Laser Mount

Rear View of the Laser Mount

Document: <http://data.sacher-laser.com/dbr/DFB0852150.pdf>
 Note: Specification are subject to change without further notice

Sacher Lasertechnik GmbH
 Hannah Arendt Str. 3-7
 D-35037 Marburg, Germany

Tel.: +49 6421 305290
 Fax: +49 6421 305299
 Email: contact@sacher.de

Sacher Lasertechnik, LLC
 5765 Equador Way
 Buena Park, CA 90620, USA

Tel.: 1-714-670-7605
 Fax: 1-714-670-7662
 Email: sales@sacher-laser.com

